

PRODUCT DATA SHEET

DS PIPE CONNECTOR DN150 / DN200

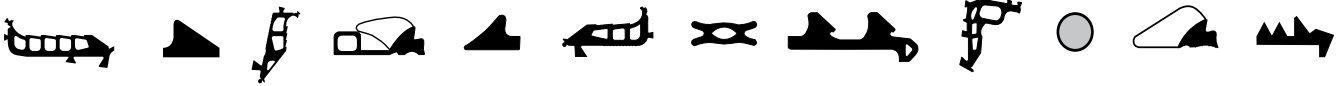

To fulfill the extremely high requirements for the connection into pipelines made out of concrete or reinforced concrete as well as clay pipes, a long lasting and secure introduction of industrial or communal sewage water has to be guaranteed. These high requirements can only be fulfilled by a connecting piece which – besides its basic functional properties – primarily is easy and uncomplicated to assemble on site.

With the successfully tested and attested DS Pipe Connector there is a product available to the market, which fulfils highest requirements to all necessary criteria completely. Denso Pipe Connector corresponds to DIN V 1825-1 for the connecting piece material polypropylene as well as to DIN EN 681-1 for the elastomer seals. Properties of the materials and functions were type tested by MPA NRW and are subject to continual production checks and third party quality monitoring.

DS Pipe Connector also has a national technical approval of German Institute for Construction Technology (DIBt).

SPECIAL ADVANTAGES

- No additional tools necessary for assembly.
- Easiest assembly: bore – lubricants – press in – finished.
- Strong seat in the main pipe.
- No projection of pipe end into main pipe by adjustment of connecting piece inbound length to the pipe wall thickness and a stop for the connecting pipe in the connecting piece.
- High sealing security by elastomer sleeve compressed in the complete pipe wall.
- High security against movement and shear loads in the connection to the main pipe through plastic ribs in the seal sleeve.

- PE-HD pipe (high density polyethylene) according to DIN 8074
- High acceptance of radial loads through all round support of the connecting piece to the main pipe by curved distance rings.
- Corrosion protection of the bored reinforcement by covering the bore hole wall with a compressed elastomer sleeve.
- Robust design.

MATERIAL

The DS pipe connector is produced from polypropylene. The seal in the connecting socket end and the sealing sleeve on the connecting pipe are normally produced from styrene butadiene rubber (SBR), hardness 40+5 IRHD. The materials resist the usual stresses caused by sewage.

In case of content of light liquids (oil, petrol, fuels) in the sewage water it is recommended to use seals in the connection socket made out of acryl-nitrile-butadiene-rubber (NBR), which has a higher resistance against light liquids.



CONDITIONS OF USE AND INSTRUCTIONS

The connector is adjusted to the pipe wall thickness and the outer diameter of the concrete pipe or clay pipe in the factory by using distance rings and a curved ring. Thereby the connector sits on the main pipe and does not project into the pipe. For the pipes made out of clay, ET or KG, to be connected to the main pipe, a stop exists.

On building projects with unknown pipe diameters and wall thickness it is possible to deliver basic connectors to the site, which can be adjusted to the existing main pipe with a few manipulations.

The relevant area of sealing got laid into the thickness of the pipe wall of the main pipe, to avoid problems caused by spallings when bored and also to guarantee a sealing of the steel reinforcement according to DIN 1045 requirement on concrete covers.

Connecting pipe				Connecting pipe STZ/concrete		Necessary bore diameter dB
DN	ST dsp	EP dsp	PVC, PP, PE dsp	DN	Wall thickness	
150	186	178	160	250 ¹ - 1500 ²	35 - 250	181 - 183
200	242	237	200	300 ¹ - 1500 ²	50 - 150	231 - 232

¹ For DN 250 & DN 300, the impact on the statics of the pipe is to be observed

² and larger (All dimensions in mm)

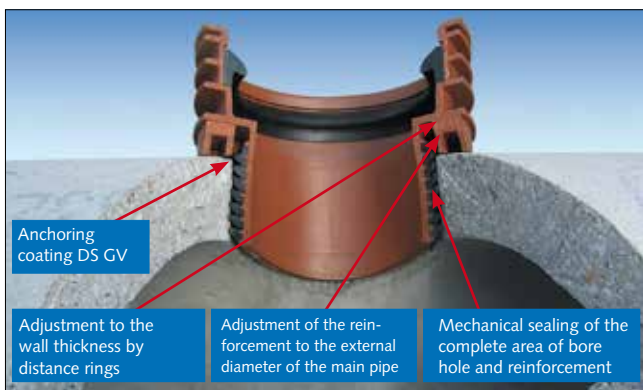

All advantages at a glance.

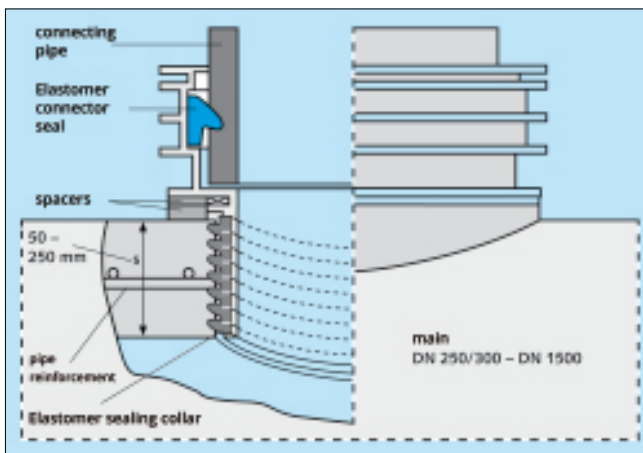

Diagram of the bore connection reinforcement

ASSEMBLY



Drill a circular hole with a diamond drill bit at right angles and centrally to the concrete pipe axis.

Bore hole diameter DN 150:
181 to 183mm

Bore hole diameter DN 200:
231 to 233 mm

We can inform you about the drill bits! Remove core and clean bored surface of dirt/dust.



Wet the whole bored surface, if dry, with a good amount of water. Allow the water to be absorbed by the bored surface, until all water drops are gone. *)



Stir DS GV – a sliding and anchoring coating – shortly in its tin with the included brush, then apply it thickly on the rubber sleeve and rub it into the bored concrete surface as well.

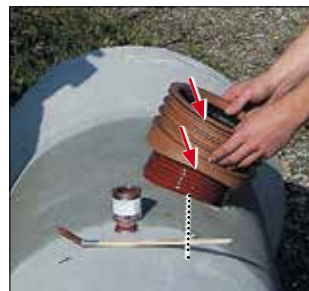

Press the pipe connector centrally – with its mark in axial direction of the pipe – into the bored hole until the stop is achieved. Central insertion is important, in order to compress the first rubber rib evenly and to avoid it turning over.



Before the mounting of the connection pipe DS GV has to be applied on the sealing ring in the socket of the connector and on the pipe spigot end. In case of a cut pipe its end has to be beveled before.

*) In the winter concrete surface has to be free of ice

The test certificate by building supervision is available on our website: www.dsseals.com.

Values and properties shown in diagrams and tables are not subject to any guarantees. Our warranty is limited to the values and properties as required by the relevant standards. Our literature, data sheets and recommendations represent our knowledge at the time of printing but are in no way legally binding on us. Our "General Conditions of Sale" apply to all sales.

DS
DICHUNGSTECHNIK